

BRONX, NEW YORK

Cross Bronx Plaza
3,016 s.f. Available



Available Space: 3,016 s.f. next to Chase

Join TJMaxx, Stop & Shop, IHOP, Auto Zone, Hook & Reel (Coming Soon!), Burger King, TMobile, Chase, Taco Bell, Rainbow, & Foot Locker.

Easy access from the Cross Bronx Expressway, where daily traffic counts exceed 153,000 vehicles per day.



Cross Bronx Plaza - 961 E 174th Street
Bronx, New York

Washington Heights CBD

Marshalls

Lucille Roberts planet fitness

blink FITNESS Staples

MODELL'S SPORTING GOODS claire's

Riverdale CBD

Marshalls TARGET planet fitness

blink FITNESS

FAMILY DOLLAR CRUNCH

Bay Plaza SC

JCPenney JENNIFER FURNITURE

Kmart Marshalls Burlington

AMC DOLLAR TREE

Staples MODELL'S SPORTING GOODS

Pier 1 imports Ashley HOMESTORE

BOB'S DISCOUNT FURNITURE

Mall at Bay Plaza SC

macy's

Bath&BodyWorks

XSPORT FITNESS

SEPHORA

Fordham Road CBD

Marshalls Burlington TJ-maxx

DOLLAR TREE Lucille Roberts 24 FITNESS

blink planet fitness MODELL'S SPORTING GOODS RBC

DOLLAR GENERAL HARBOR FREIGHT TOOLS

planet fitness

Staples

Gun Hill Commons

DOLLAR TREE CHUCK E. CHEESE'S petco

planet fitness THE HOME DEPOT

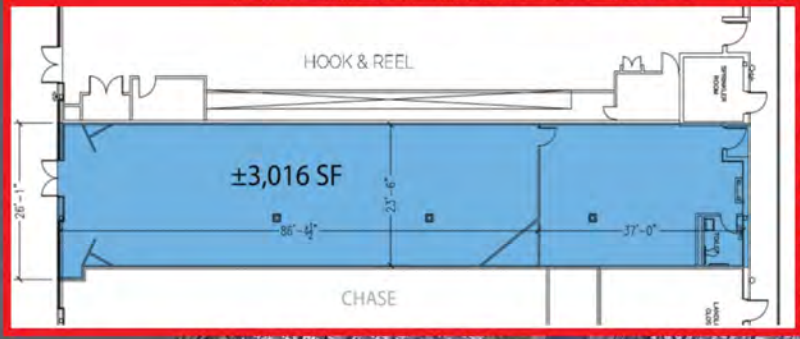

Cross Bronx Plaza
AVAILABLE - 3,016 SF

Stop&Shop Foot Locker TACO BELL

IHOP TJ-maxx BURGER KING

HOOK & REEL Auto Zone

CAJUN SEAFOOD & BAR

1 mi radius

SITE

LA FITNESS

NYSO POWERHOUSE GYM

macy's

Marshalls

blink FITNESS

MODELL'S SPORTING GOODS

planet fitness

Throgs Neck SC

TARGET TJ-maxx petco

DOLLAR TREE

DOLLAR GENERAL

planet fitness blink FITNESS

Southern Blvd CBD

DOLLAR TREE DOLLAR GENERAL

blink planet fitness RBC

planet fitness

Shops at Brucker Commons

Marshalls Kmart Burlington

sears MODELL'S SPORTING GOODS

Bronx Terminal Market

Burlington TARGET

CHUCK E. CHEESE'S THE HOME DEPOT

Marshalls

BED BATH & BEYOND BJS WHOLESALE CLUB

THEATRES blink FITNESS

MODELL'S SPORTING GOODS

THE HUB

Marshalls Burlington

DOLLAR TREE FAMILY DOLLAR

planet fitness blink FITNESS MODELL'S SPORTING GOODS

Demographics	1 mile	3 miles	5 miles
Population	160,606	1.29 M	2.18 M
Households	55,962	463,027	838,030
Average HH Income	\$43,421	\$54,324	\$70,144
Median Age	31.7	33.3	35

WELCO REALTY, INC.